

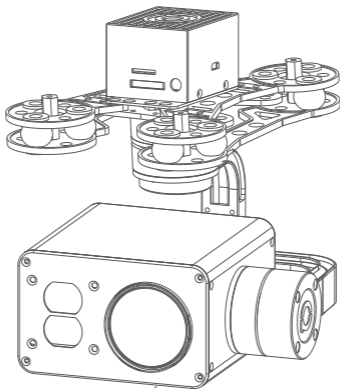

## User manual

### Z30T-M

30x Zoom Laser Night Vision Object Tracking Camera Gimbal



Images are for reference only, please subject to the actual product.

# Contents

## Z30TM Pinpoint-precision Gimbal

1. Gimbal introduction .....	2
2. Object tracking function .....	2
3. Gimbal description .....	3
4. Packing list .....	4
5. Gimbal dimension .....	4
6. Installing .....	5
7. Mechanics@Electronic characteristics .....	5
8. Working characteristics .....	5
9. Gimbal's signal wire box .....	6
10. Gimbal's connection of control box and wiring instructions .....	7

## 30x Starlight HD Zoom Camera

1. 30x Starlight camera introduction .....	11
--	----

## GPS Information Display and Serial Port Control Wiring Diagram

1. GPS and Connection of control box.....	13
2. GPS baud rate .....	13
3. Gimbal description .....	13

## Gimbal Introduction

Z30TM is a pinpoint-precision professional 3-axis gimbal which features high stability, small size, light weight and low power consumption. The 3-axis gimbal based on FOC motor control technology, adopts pinpoint-precision encoder in each motor.

The speed of Z30TM gimbal is adjustable, LOW speed mode is used for large zoom range, the control will be more accurate; Fast speed mode is used for small zooming range, which makes the gimbal control sensitive and quick. Also the one-key to center function will allow the gimbal return to initial position automatically and rapidly.

Z30TM supports PWM, S.BUS and serial command control, suitable for close range remote control or remote data command control.

## Object Tracking Function

### 1. Function description

Build-in normalization, cross-correlation and tracking algorithm, combining with object missing recapture algorithm, achieve stable track of the target.

Support custom characters of user OSD, adaptive gate, cross cursor, tracking information display.

### 2. Tracking Performance

- 1)Update rate of deviation pixel 50Hz
- 2)Output delay of deviation pixel <10ms
- 3)Minimum object contrast 5%
- 4)The minimal signal-to-noise ratio (SNR) 4
- 5)Minimum object size 16\*16 pixel
- 6)Maximum object size 160\*160 pixel
- 7)Tracking speed 32 pixel/frame
- 8)The mean square root values of pulse noise in the object position<0.5 pixel
- 9)Object memory time 100 frames

## Gimbal Description

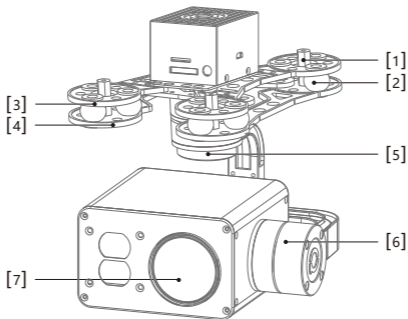

[1] Gimbal fixed copper cylinder

[6] Pitch axis motor

[2] Damping balls

[7] HD zoom camera

[3] Upper damping board

[4] Lower damping board

[5] YAW axis motor



Please make sure that the motor is not stopped by any object during the rotation, if the gimbal is blocked during rotation, please remove the obstruction immediately.

## Packing list

Gimbal\*1

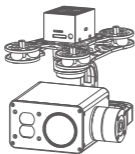

Screw pack\*1

Screw pack\*1  
(M3\*5mm button head hexagon screw\*12)

Copper cylinders\*4



Damping balls\*12



## Gimbal Dimension

Unit : mm

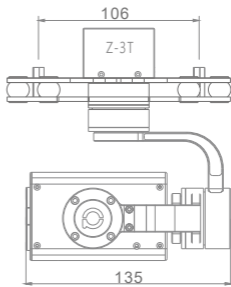
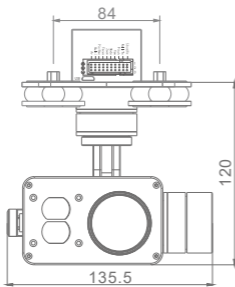

## Installing

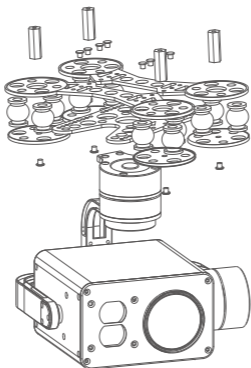

### Mechanics@Electronic Characteristics

Input voltage	3S~ 4S	Idle current	330mA@12V
Dynamic current	450mA@12V	Working environment temp	-20 C ~ +80 C
Size	L135.5 *W 135*H120mm	Weight	835g

### Working Characteristics

Pitch/Tilt: Pitch angle range of action : $\pm 90$
Roll: Roll angle range of action : $\pm 85^{\circ}$
Yaw/Pan: Yaw angle range of action : $\pm 150^{\circ}$
Vibration angle: Pitch/Roll: $\pm 0.02^{\circ}$ , Yaw: $\pm 0.03^{\circ}$

# Gimbal's Signal Wire Box

Size:49\*45.4\*35.7

Unit : mm

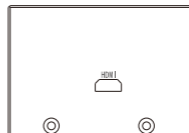
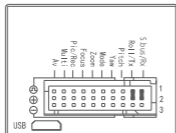
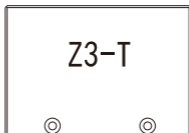
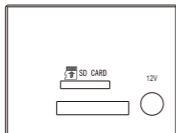
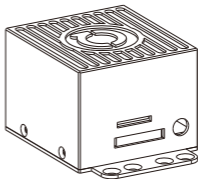
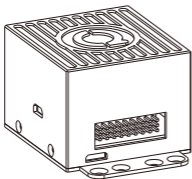

## Connection of Control Box and Wiring Instruction

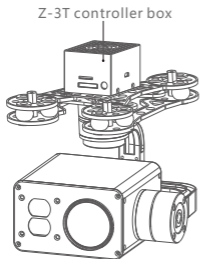

HDMI: micro HDMI OUTPUT  
1080P 60fps default  
SD card: max 128G, class10  
FAT32 or exFAT format

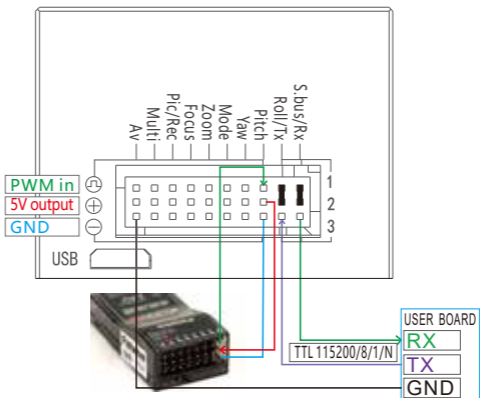

S.bus/Rx: connect to Rx2 for track function.

Roll/ Tx: connect to Tx2 for track function.

Pitch: PWM in, pitch control

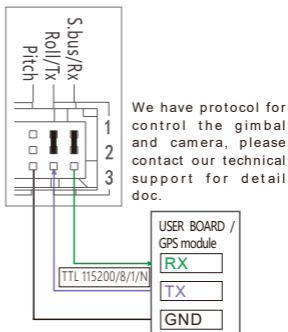
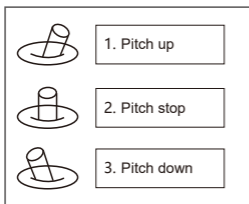

Yaw: PWM in, Yaw control



Mode: Change the speed / home position

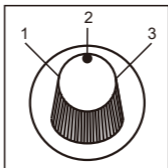

Position 1: Lowest speed for pitch and yaw.

Position 2: Middle speed for pitch and yaw.

Position 3: Highest speed for pitch and yaw. The speed is continuously quickly from 1 to 3.

One click: Home position.

Two click: Look down.

Three click: Yaw not followed by frame.

Four click: Yaw followed by frame.

Five click: Restore the factory settings.

(Click = from 2 to 3 and back to 2 quickly)

ZOOM: Zoom the camera

Focus: Focus the camera



1. Zoom tele



2. Stop zoom



3. Zoom wide



1 Focus tele



2 Stop focus



3 Focus near

## Pic /Rec picture / Start record, stop record

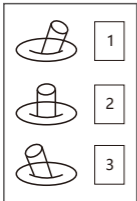

Switch 2 to 1: Start record / stop record.start record, the OSD display rec hh:mm:ss ;

Stop record, the OSD display STBY.

Switch 2 to 3: take a picture . OSD display'REC IMG' a second.

## Multi: Tracking control / camera ICR on, laser on/ camera ICR off, laser off

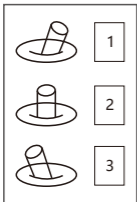

1. Position 1 exit the tracking

Switch 1 to 2: Display the cross cursor. Adjust the object to the cross cursor.

2. Switch 2 to 3: start tracking. Change the object during tracking

Switch 3 to 2: Display the cross cursor, use Pitch/Yaw to adjust the cross cursor.

Switch 2 to 3: Start tracking.

AV: NO AV output this model.

## SONY EV7520 30x Starlight Camera

		<b>FCB-EV7520</b>
Imager sensor		1/2.8-type Exmor R CMOS
Lens		30x
Picture quality		Full HD 1080p (1920 x 1080)
Minimum illumination*		Colour: 0.01 lx (F1.6, AGC on, 1/30 s)
Digital zoom		12x (360x with optical zoom)
Defog		Yes
Image sensor		1/2.8-type Exmor R CMOS
Image sensor (Number of effective pixels)		Approx. 2.13 Megapixels
Signal system		1080p/59.94, 1080p/50, 1080p/60, 1080p/30, 1080p/29.97, 1080p/25, 1080i/59.94, 1080i/50, 1080i/60, 1080i/30, 720p/59.94, 720p/50, 720p/60, 720p/30, 720p/29.97, 720p/25, NTSC*1, PAL*1
Minimum illumination (50%)	High sensitivity mode	Colour: 0.01 lx (F1.6, AGC on, 1/30s)
	Normal mode	Colour: 0.1 lx (F1.6, AGC on, 1/30s)
S/N ratio		More than 50 dB
Gain		Auto/Manual 0 dB to 50.0dB (0 to 28 steps +2 step/ total 15 steps) Max. Gain Limit 10.7 dB to 50.0 dB (6 to 28 steps +2 tep/total 12 steps)

		<b>FCB-EV7520</b>
Shutter speed		1/1 s to 1/10,000 s, 22 steps
Sync system		Internal
Exposure control		Auto, Manual, Priority mode (shutter priority & iris priority), Bright, EV compensation, Slow AE
Backlight compensation		Yes
Aperture control		16 steps
White balance		Auto, ATW, Indoor, Outdoor, Outdoor Auto, Sodium Vapor Lamp (Fix/Auto/Outdoor Auto), One-push, Manual
Lens		30x optical zoom f = 4.3 mm (wide) to 129.0 mm (tele) F1.6 to F4.7
Digital zoom		12x (360x with optical zoom)
Focusing system		Auto (Sensitivity: normal, low), One-push AF, Manual, Interval AF, Zoom Trigger AF, Focus compensation in ICR on
Horizontal viewing angle	1080p mode	63.7° (wide end) to 2.3° (tele end)
	720p mode	63.7° (wide end) to 2.3° (tele end)
	SD	47.8° (wide end) to 1.7° (tele end)
Minimum object distance		10 mm (wide end) to 1200 mm (tele end) (Default: 300 mm)